

GAS CONVERSION KIT INSTALLATION INSTRUCTIONS

These instructions apply to the following gas conversion kits:

8261145	8261905
8261146	8261906
8261147	8261907
8261148	8261908
8261904	8261909

These kits are not for altitudes over 2000 feet.

WARNING

This conversion kit shall be installed by a qualified service agency in accordance with the manufacturer's instructions and all applicable codes and requirements of the authority having jurisdiction. If the information in these instructions is not followed exactly, a fire, an explosion or production of carbon monoxide may result causing property damage, personal injury or loss of life. The qualified service agency is responsible for the proper installation of this kit. The installation is not proper and complete until the operation of the converted appliance is checked as specified in the manufacturer's instructions supplied with the kit.

AVERTISSEMENT

Cette trousse de conversion doit être installée par un service d'entretien qualifié, selon les instructions du fabricant et selon toutes les exigences et tous les codes pertinents de l'autorité compétente. Assurez-vous de bien suivre les instructions dans cette notice pour réduire au minimum le risque d'incendie, d'explosion ou la production de monoxyde de carbone pouvant causer des dommages matériels, des blessures ou la mort. Le service d'entretien qualifié est responsable de l'installation de cette trousse. L'installation n'est pas adéquate ni complète tant que le bon fonctionnement de l'appareil converti n'a pas été vérifié selon les instructions du fabricant fournies avec la trousse.

These instructions apply to the kits listed in the table below. **Before beginning installation, verify the kit number on the package is correct for the intended appliance.**

<p align="center">Natural to Propane Gas Conversion Kits 8261906 and 8261908</p> <p align="center">For use in FBR18/24-FBRA18/24 Rethermalizers and GSMS/GBC/GC Cookers</p>	
<i>The principal components of these kits are:</i>	
2	2.00MM Burner Orifices P/N 8100917
2	Ignitor P/N 8100608
2	Ignitor Gasket P/N 8160165
1	Regulator Conversion Kit P/N 8071848
BTU Rating: 80,000 BTU	

<p align="center">Propane to Natural Gas Conversion Kit 8261907 and 8261909</p> <p align="center">For use in FBR18/24-FBRA18/24 Rethermalizers and GSMS/GBC/GC Cookers</p>	
<i>The principal components of these kits are:</i>	
2	3.26MM Burner Orifices P/N 8100916
2	Ignitor P/N 8100521
2	Ignitor Gasket P/N 8160165
1	Regulator Conversion Kit P/N 8071847
BTU Rating: 80,000 BTU	

<p align="center">Natural to Propane Gas Conversion Kit 8261904</p> <p align="center">For use in G18FB and G24FB Series Fryers</p>	
<i>The principal components of this kit are:</i>	
2	1.90MM Burner Orifices P/N 8100466
2	Ignitor P/N 8100608
2	Ignitor Gasket P/N 8160165
2	Ignitor Box Gaskets P/N 8160054
1	Regulator Conversion Kit P/N 8071848
BTU Rating: 80,000 BTU	

<p align="center">Propane to Natural Gas Conversion Kit 8261905</p> <p align="center">For use in G18FB and G24FB Series Fryers</p>	
<i>The principal components of this kit are:</i>	
2	3.05MM Burner Orifices P/N 8100465
2	Ignitor P/N 8100521
2	Ignitor Gasket P/N 8160165
2	Ignitor Box Gaskets P/N 8160054
1	Regulator Conversion Kit P/N 8071847
BTU Rating: 80,000 BTU	

<p align="center">Natural to Propane Gas Conversion Kit 8261145</p> <p align="center">For use in Full Vat H50, H52 and H55 Series Fryers</p>	
<i>The principal components of this kit are:</i>	
2	2.10MM Burner Orifices P/N 8100386
2	2.10MM Burner Orifices P/N 8101126
2	Ignitor Kits P/N 8260982
2	Burners P/N 8100687
2	Burner Insulation Kits P/N 8260931
1	Regulator Conversion Kit P/N 8071848
BTU Rating: 80,000 BTU	

<p align="center">Propane to Natural Gas Conversion Kit 8261146</p> <p align="center">For use in Full Vat H50, H52 and H55 Series Fryers</p>	
<i>The principal components of this kit are:</i>	
2	3.40MM Burner Orifices P/N 8100403
2	3.40MM Burner Orifices P/N 8101132
2	Ignitor Kits P/N 8260981
1	Regulator Conversion Kit P/N 8071847
BTU Rating: 80,000 BTU	

**Natural to Propane Gas Conversion Kit
8261147
For use in Dual Vat H50, H52 and H55
Series Fryers**

The principal components of this kit are:

- | | |
|---|---------------------------------------|
| 2 | 2.10MM Burner Orifices P/N 8100386 |
| 2 | 2.10MM Burner Orifices P/N 8101126 |
| 2 | Ignitor Kits P/N 8260982 |
| 2 | Burners P/N 8100687 |
| 2 | Burner Insulation Kits P/N 8260932 |
| 2 | Regulator Conversion Kits P/N 8071848 |

BTU Rating: 40,000 BTU

**Propane to Natural Gas Conversion Kit
8261148
For use in Dual Vat H50, H52 and H55
Series Fryers**

The principal components of this kit are:

- | | |
|---|---------------------------------------|
| 2 | 3.40MM Burner Orifices P/N 8100403 |
| 2 | 3.40MM Burner Orifices P/N 8101132 |
| 2 | Ignitor Kits P/N 8260981 |
| 2 | Regulator Conversion Kits P/N 8071847 |

BTU Rating: 40,000 BTU

 **CAUTION**

The gas supply shall be shut off prior to disconnecting the electrical power, before proceeding with the conversion.

 **ATTENTION**

Avant d'effectuer la conversion, couper d'abord l'alimentation en gaz, ensuite couper l'alimentation électrique.

Installation Instructions

- 1) Shut off the gas supply to the appliance and disconnect the appliance from the electrical power supply.
- 2) Remove the burners in accordance with the instructions in the Service and Parts Manual for the specific appliance being converted.
- 3) Remove the existing burner orifices and replace them with those in the kit.

NOTE 1: In H50, H52 and H55 Series fryers **being converted to propane gas**, the burners must also be replaced with those in the kit.

- 4) Reinstall the burners in accordance with the instructions in the Service and Parts Manual for the specific appliance being converted. For H50, H52 and H55 Series fryers being converted to propane gas, replace the burner insulation with that in the kit.
- 5) Remove the ignitor and ignitor gasket in accordance with the instructions in the Service and Parts Manual for the specific appliance being converted and replace them with those in the kit. (**NOTE:** Ignitor assemblies and orifices for propane are red. Ignitor assemblies and orifices for natural gas are blue.)
- 6) FOR G18FB AND G24FB FRYERS ONLY, replace the ignitor box gasket.
- 7) Remove the cap screw covering the pressure regulator spring of the gas valve.
- 8) Remove the pressure regulator adjustment screw and spring from the gas valve.
- 9) Install the replacement spring and adjustment screw furnished with the kit. (**NOTE:** If the spring is tapered, the small end goes down. Springs for use with propane gas are black. Springs for use with natural gas are silver. The adjustment screw for either type gas is black.)
- 10) Apply the gas conversion sticker next to the existing rating plate stating the gas has type have been converted on the inside of the appliance door(s). Remove any references to the previously used gas from the existing rating plate.

- 11) Shut off the gas supply.
- 12) Check the incoming gas pressure by removing the inlet tap.
- 13) Attach a manometer to the inlet tap.
- 14) Open the gas supply.
- 15) Verify that the incoming gas pressure is in accordance with the appropriate table below for the appliance being converted. If the pressure is too high or low call the local gas company to adjust the incoming gas pressure.

Gas	Minimum	Maximum
Natural	7" W.C.	10.5" W.C.
LP	11" W.C.	13.5" W.C.

- 16) Remove the manometer and replace the tap.
- 17) Open the gas supply to the appliance and check for leaks using a solution of soapy water applied to each connection in the appliance's gas supply system.
- 18) Ensure the gas valve knob is in the OFF position.
- 19) Locate and remove pressure tap plug.
- 20) Attach a manometer to the gas valve pressure tap then reconnect the appliance to the electrical power supply.
- 21) Verify that there is cooking oil or water in the frypot or cookpot.
- 22) Place the gas valve in the ON position.
- 23) Place the fryer power switch in the ON position. When the burner has lit and burned steadily for at least one minute, compare the gas pressure reading to table on page 8 of these instructions.
- 24) To adjust the manifold gas pressure, remove the cap from the gas valve regulator and adjust it to the correct pressure.
- 25) When the pressure has been verified as correct, shut down the fryer and install the cap furnished with the kit over the regulator adjustment screw. (**NOTE:** Caps for use with propane gas are black. Caps for use with natural gas are silver.)
- 26) Verify correct BTU by ensuring that the manifold gas pressure is correct. The proper manifold pressures are listed in the table on page 7 of these instructions.
- 27) Shut off the gas supply to the fryer, disconnect the manometer, and reinstall the pressure tap plug. Open the gas supply. Use a solution of soapy water to verify the plug is not leaking.
- 28) Turn on the fryer to light the burners. Verify proper operation of the fryer in accordance with the instructions in the Installation and Operation Manual.
- 29) The standard operating sequence of the ignition system is:
 - a. The fryer calls for heat.
 - b. The blower starts.
 - c. The gas valve opens.
 - d. The ignitor sparks.
 - e. The burner lights.
 - f. The flame sensor senses the flame.
 - g. Viewing through the flame through the burner sight glass (see photo below) reveals the radiants of the burner glow blue at startup. After 1 minute, a bright orange glow should appear. If the burner remains blue, it is an indication of an improper gas/air mixture. No pilot adjustment is needed on a direct spark ignition.
- 29) When the burner flame is properly adjusted by adjusting the air shutter on the blower it will produce a current between 2.5 μ A and 3.5 μ A.
- 30) Test the microamps by placing the fryer power switch in the OFF position.
- 31) Disconnect the sensing wire from one of the burner ignitors and connect it to the positive lead of a meter. Connect the negative lead of the meter to the terminal from which the sensing wire was removed.

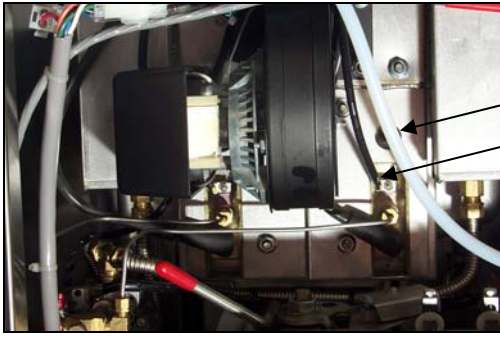

Burner Sight Glass

Flame Sensor Wire

- 32) Place the fryer power switch in the ON position to light the burners. After the frypot temperature reaches 200 °F (93°C), wait at least one minute before checking the reading. **NOTE:** The closer the unit is to normal operating temperature, the more accurate the reading will be.
- 33) Once adjusted, remove leads and reconnect flame sensor wire.

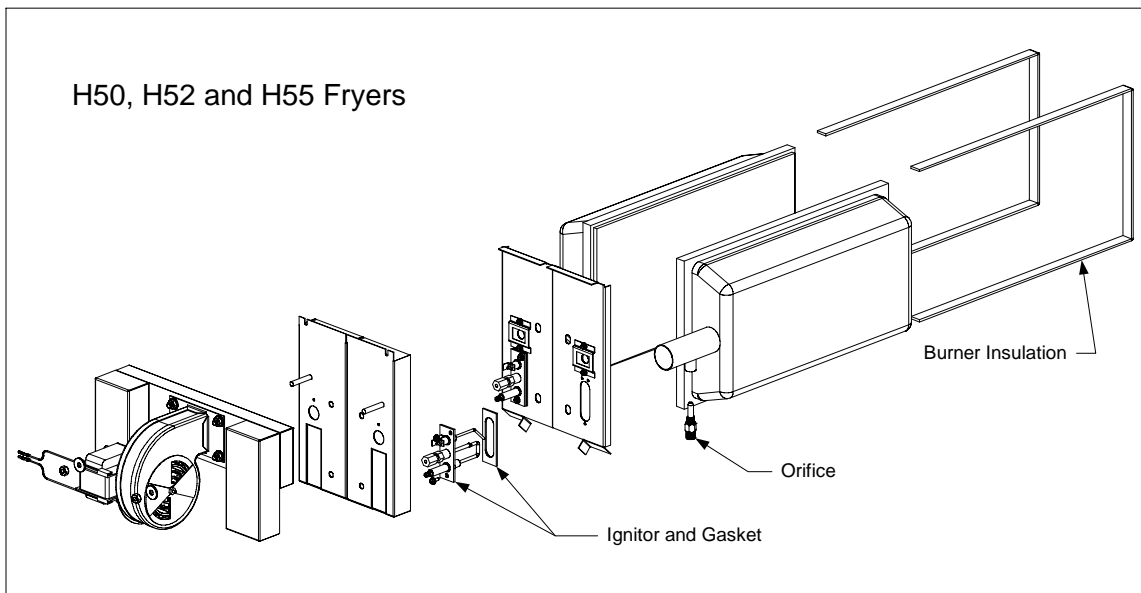
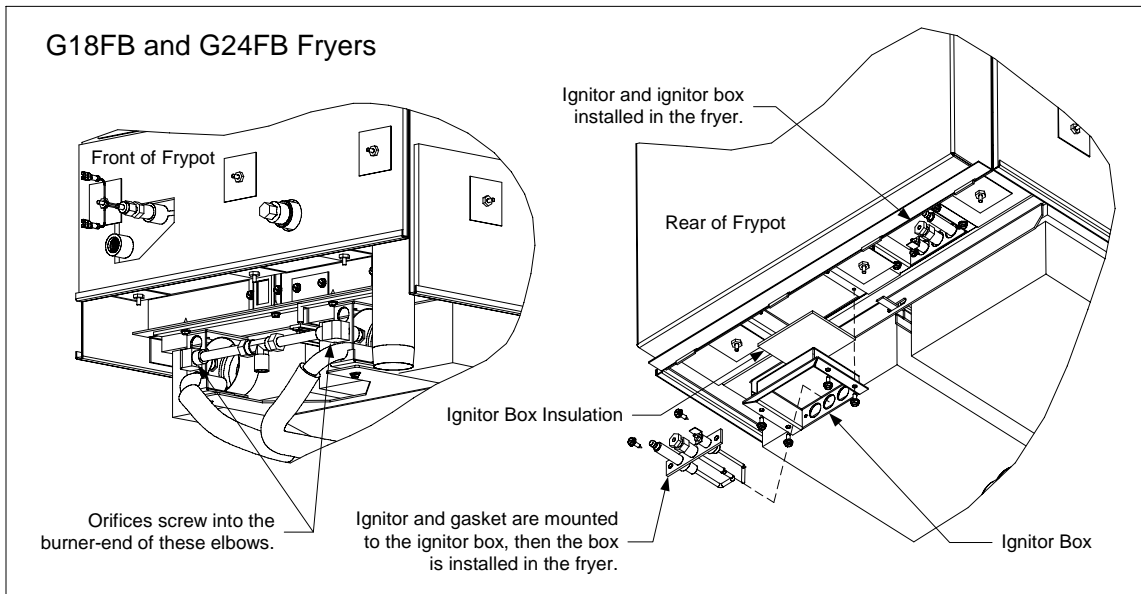
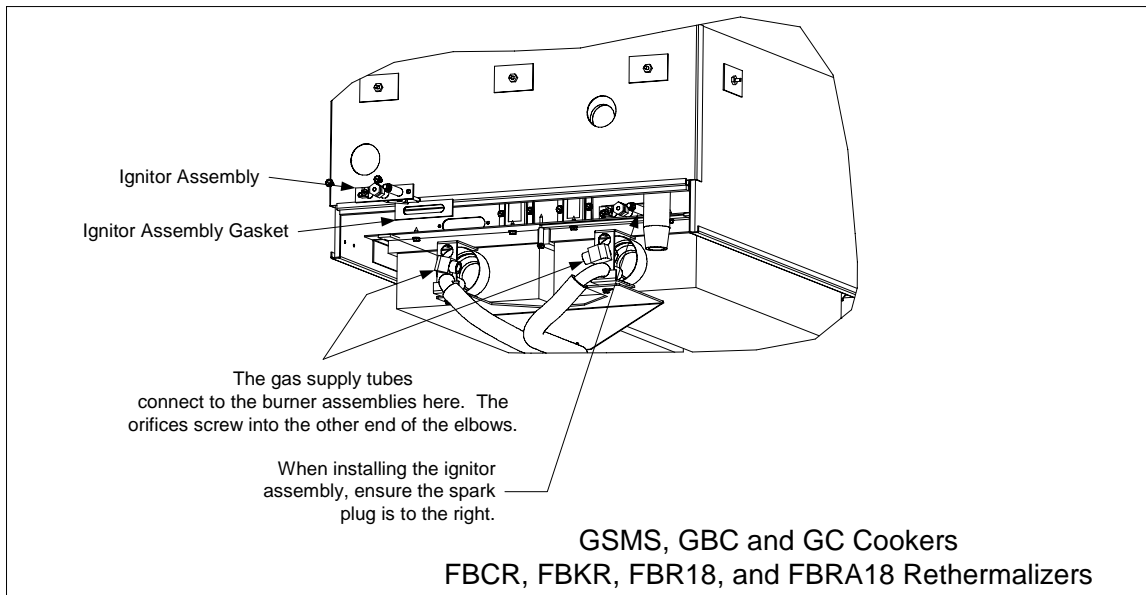

Manifold Pressures

FBR18/24, FBRA 18/24, G18FB, G24FB, H50, H52 and H55 models

Burner Manifold Gas Pressures	
Gas	Pressure
Natural	3" W.C. 0.73 kPa
Propane	8.25" W.C. 2.5 kPa

TEAR OFF SHEET

THIS APPLIANCE IS EQUIPPED FOR NATURAL (PROPANE) (LP) GAS

This appliance is equipped with orifices sized for operation with natural (PROPANE) (LP) gas.

For conversion to LP (propane) (natural) gas see instruction plate on the appliance.

Orifices necessary for LP (propane) (natural) conversion are provided in the kit.